

# Outdoor distribution cabinet

24U 600x600 RACK 19" STZ

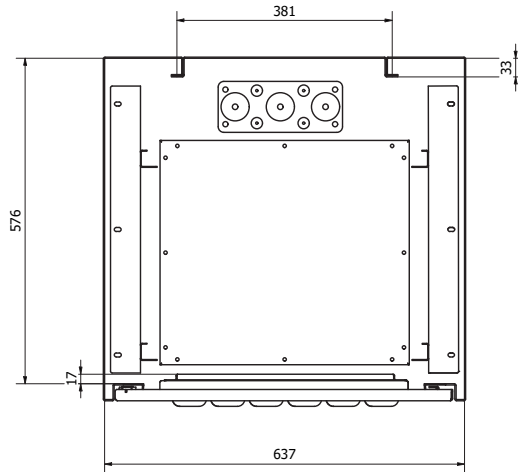

PRODUKT  
POLSKI  
ID: 8662

This entirely laser-welded, all-aluminium cabinet provides high resistance against dust and water, protecting the equipment inside. The cabinet is available in two standards, the default IP 65 and the increased Ingress Protection Rating 66. The Impact Protection Rating of the cabinet is IK 09.

The impermeability of the cabinet is achieved through three elements:

- Gasket - poured polyurethane on the doors, when closed tightly it adheres to the flange in the corpus of the cabinet, the flange is profiled at an 88 degree angle to form a drainage channel for water that gets between the door and the corpus.
- A separating and filtering cassette is mounted on the cabinet door protecting against 100 l/min water jets according to PN-EN 60529 standard and a filtering permeability class M5 mat acting as a barrier against dust
- A separating cassette in the cabinet's roof protecting against 100 l/min water jets in accordance with EN 60529

Three supporting elements are used to mount the equipment inside the cabinets:

- Front rack rails spread 19" wide, front – back 135 mm adjustable
- Back rack rails spread 19" wide, front – back 135 mm adjustable
- Supporting strips on the rear panel with standard m6 threaded holes, 380 mm wide between holes, 5 kg load capacity per hole.

Cabinet doors are mounted on steel internal hinges, locked with a four-point bolting mechanism implemented outside the cabinet chamber (unique patent-pending bolting system). Handle with cylinder lock, possible change of cylinder lock by the user.

A „MOREK” cable grommet with IP66 protection rating is used for cable routing into the enclosure. The cable is introduced into the cabinet by a removable floor panel. A sealing gasket is poured in between the panel and the floor to maintain impermeability.

There is space in the roof of the cabinet for mounting an accessory ventilation panel to ensure heat dissipation. The choice of ventilation panel depends on the requirements of the devices installed inside.

The cabinet is designed to be placed on an adapted steel or aluminium base supplied by the manufacturer as a mounting accessory, or on any self-made concrete base.

No special sealing is required at the connection between the cabinet and the base.

|                                    |                   |
|------------------------------------|-------------------|
| Rack rail height                   | 24U               |
| Distance between rack rails [inch] | 19"               |
| Height [mm]                        | 1384              |
| Width [mm]                         | 641               |
| Depth [mm]                         | 625               |
| Internal dimensions [mm]           | 1160 x 637 x 576  |
| IP rating                          | IP65 (IP66)       |
| IK rating                          | IK09              |
| Sheet thickness [mm]               | 2                 |
| Material                           | Aluminium PA11    |
| Maximum load [kg]                  | 400               |
| Doors [pcs]                        | 1                 |
| MOREK                              | 1                 |
| Hermetic lock [pcs]                | 1                 |
| Gasket                             | cast polyurethane |
| Color                              | RAL7035           |
| Weight [kg]                        | 43                |
| Corrosion warranty [year]          | 25                |